

Dynamic Optimization of a Multimachine Power System with a FACTS Device Using Identification and Control ObjectNets

Ganesh K. Venayagamoorthy
Department of Electrical and Computer Engineering
University of Missouri-Rolla
MO 65409, USA
gkumar@ieee.org

Abstract — This paper presents a novel technique for dynamic optimization of the electric power grid using brain-like stochastic identifiers and controllers called *ObjectNets* based on neural network architectures with recurrence. *ObjectNets* are neural network architectures developed to identify/control a particular object with a specific objective in hand. The IEEE 14 bus multimachine power system with a FACTS device is considered in this paper. The paper focuses on the combined minimization of the terminal voltage deviations and speed deviations at the generator terminals and the bus voltage deviation at the point of contact of the FACTS device to the power network. Simulation results are provided for the identifier and controller *ObjectNets* for the generators and the FACT device.

Keywords –*Dynamic optimization, recurrent neural networks, multimachine power system, FACTS, generators, identification, control, scalability, multi-agents*

I. INTRODUCTION

Recently, intelligent techniques and adaptive critic designs have received increasing attention [1, 2, 3]. The dynamic stochastic optimization (DSO) of complex systems such as the electric power grid and its parts can be formulated as minimization and/or maximization of certain quantities. The electric power grid is faced with deregulation and an increased demand for high-quality and reliable electricity for our digital economy, and coupled with interdependencies with other critical infrastructures, it is becoming more and more stressed. Intelligent systems technology will play an important role in carrying out DSO to improve network efficiency and eliminate congestion problems without seriously diminishing reliability and security.

Optimization of the power system has been carried out offline or based a time snapshot. With the power system's fast changing complex dynamics, it is essential to carry out dynamic optimization. This is a difficult task to accomplish due to number of variables involved even with the conventional multi-agent system design. The North American power system is referred to as the largest, most complicated single machine ever built by man with thousands of variables to be controlled and optimized. The IEEE 14 bus multimachine power system with a Unified Power Flow Controller (UPFC) FACTS device is considered in this paper to demonstrate the concepts of dynamic optimization which is feasible for large networks using upgraded component

networks – the *ObjectNets*. This paper presents the dynamic optimization of a power network using brain-like stochastic identifiers and controllers called *ObjectNets* based on neural network architectures with recurrence [4]. *ObjectNets* are neural network architectures developed to identify/control a particular object with a specific objective in hand. The paper focuses on the combined minimization of the speed deviations and terminal voltage deviations at the generator terminals and the bus voltage deviation at the point of contact of the UPFC to the power system.

The primary contributions of this paper are:

- the use of adaptive critic designs for the *dynamic optimization* of a number of variables in a multimachine power system;
- the deployment of the concept of *ObjectNets* in the realization of identifiers and controllers for the all generators' terminal voltage and speed deviations, and the UPFC's shunt bus voltage and dc capacitor voltage;
- laying out of a framework to carry out dynamic optimization of hundreds of variables in large networks such as the North American power system.

The rest of the paper is outlined as follows: Section II describes the IEEE 14 bus power system; Section III describes the dynamic optimization carried out; Section IV explains the implementation of the *ObjectNets* based identifiers and controllers; Section V presents some results for the *ObjectNet* identifiers, critic network and *ObjectNet* controllers. Finally, conclusion and future work is given in Section VI.

II. MULTIMACHINE POWER SYSTEM

To illustrate the effectiveness of dynamic optimization using *ObjectNets*, the IEEE 14-bus power system is simulated in PSCAD/EMTDC environment. This power system shown in Fig. 1 comprises of two synchronous generators providing real power at buses 1, 2 and three synchronous generators providing reactive power at buses 3, 6 and 8.

The two generators G1 and G2 have excitation systems, turbines, AVR and governor controllers installed on them. The other three generators G3, G4 and G5 have only excitation system with the AVR controllers installed. The UPFC FACTS device is installed between bus 2 and bus 3 as shown in Fig. 1. The choice of location of the UPFC is not within the scope of this paper.

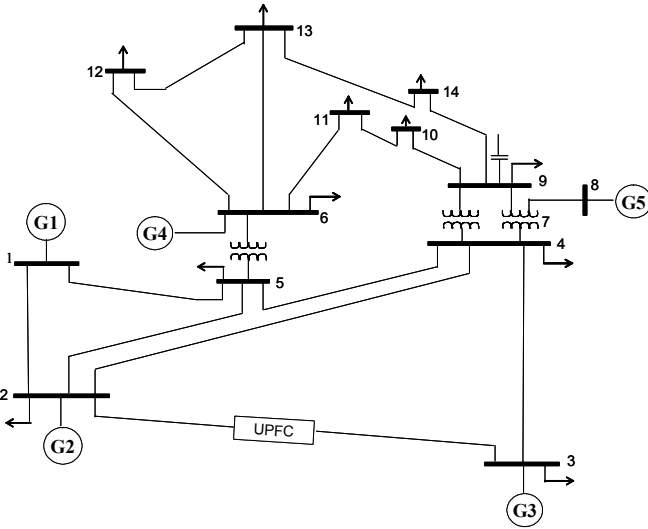

Figure 1. The IEEE14 bus power system with a FACTS device installed between bus 2 and 3.

The AVR and exciter combination transfer function block diagram is similar for all generators and is shown in Fig. 2. The turbine and governor transfer function block diagram is shown in Fig. 3.

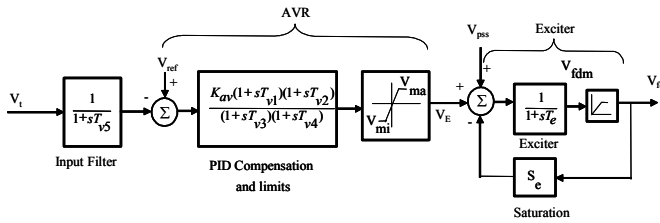

Figure 2. The AVR-exciter combination installed on all generators in Fig. 1.

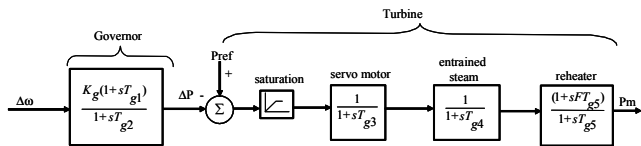

Figure 3. The governor-turbine combination installed on generators G1 and G2 in Fig. 1.

UPFC consists of two converters combined by a common DC link as shown in Fig. 4 [2, 3, 5]. The series inverter provides the main function of the UPFC by injecting a voltage with magnitude V_{ser} , which is controllable and a phase angle α in series with the line via an insertion transformer. The basic function of shunt converter is to generate or absorb the real power demanded by series inverter at the common dc link. This power demand by the series converter at the dc link is converted back to ac by the shunt converter and fed to the transmission line bus via a shunt-connected transformer. Three main control parameters of UPFC are voltage magnitude, voltage angle and shunt reactive current. The control structure of shunt and series converters is shown in Figs. 5 and 6

respectively. More details on the UPFC operation is given in [2, 3].

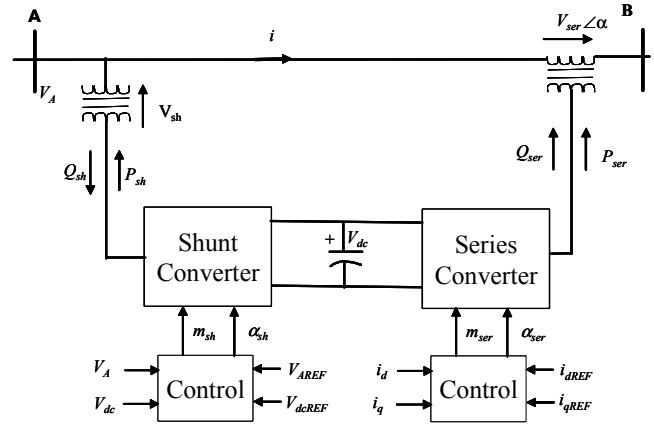

Figure 4. The UPFC implementation by two back-to-back voltage source converters installed between generators G2 and G3 in Fig. 1.

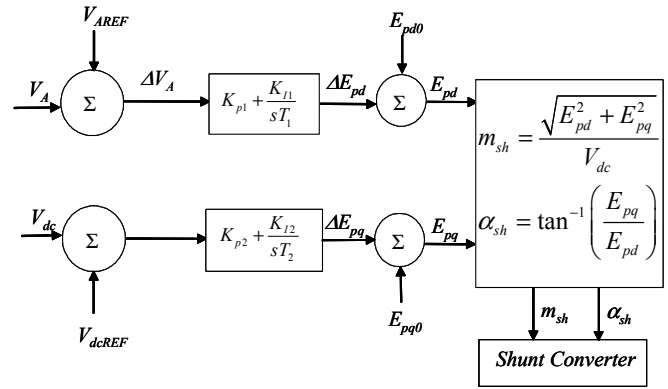

Figure 5. The UPFC shunt converter control.

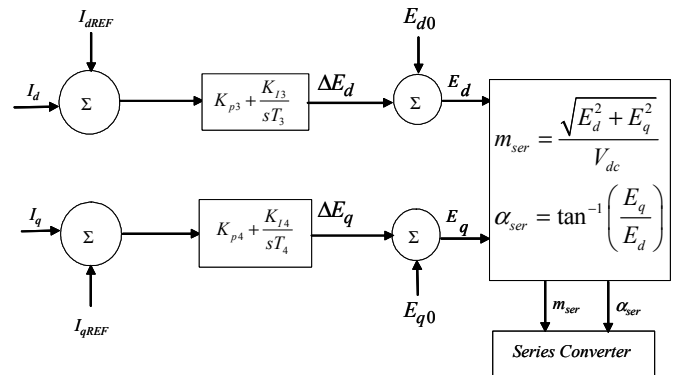

Figure 6. The UPFC series converter control.

The parameters of the conventional PI AVR, governor and, UPFC series and shunt PI controllers are determined around an one operating region of the power system and it is generally a difficult task to determine the parameters of all these controllers such that a global objective is achieved at all times whether minimization of speed, power or terminal voltage deviations during transient and normal changes in operation

conditions. Traditionally, a sequential tuning of the controllers is carried out to set the parameters at the respective operating points. The performance of the controllers will degrade once the operating conditions in power system change or a large disturbance is seen.

III. DYNAMIC OPTIMIZATION WITH ADAPTIVE CRITICS

This paper proposes the use of adaptive critic designs to carry out the dynamic optimization of power system in Fig. 1. Details on adaptive critic designs are given in the previous work of the author [6, 7]. The objective of the critic network is to dynamically optimize the parameters of the different controllers on the power system in order to minimize the combined deviations of all the generators' speed ($\Delta\omega$) and terminal voltage (ΔV_t), and the UPFC shunt bus voltage (ΔV_A) which is expressed by (1). In other words, the global objective is to ensure transient and dynamic rotor angle and voltage stability of the generators and the UPFC shunt bus during the power system operation [8].

$$J(k) = \min \left(\sum_{i=1}^5 (\Delta\omega_i + \Delta V_{ti}) + \Delta V_A \right) \quad (1)$$

The schematic block diagram for the dynamic optimization of the IEEE 14 bus power system (plant) using the critic network is shown in Fig. 7.

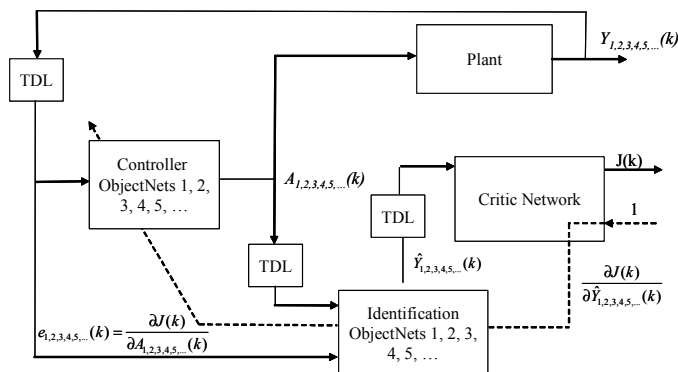

Figure 7. Block diagram for the dynamic optimization of the different controllers (developed using the ObjectNets) using a critic network. TDL means Tapped Delay Line.

Three different recurrent neural networks (RNNs) based agents are used, namely one for the critic network, another one for identification of the system dynamics at the respective device/unit (generator, FACTS) and the last one for controlling the device of the power system. This proposed architecture is based on the Heuristic Dynamic Programming (HDP) approach of adaptive critic designs [9].

The inputs to the critic recurrent neural network are outputs of the identification networks over a number of time instances from various devices of the power system to be controlled optimally. In this paper, the inputs to the critic network for the IEEE 14 bus power system are namely: the predicted terminal

voltage deviations of G1, G2, G3, G4 and G5, speed deviations of G1, G2, G3, G4 and G5, and the voltage deviation at the UPFC shunt bus (V_A) for next time instance, $k+1$. The total number of inputs is 34 including the predicted outputs at time instance k and $k-1$ and the bias input as shown in Fig. 8. A recurrent neural network of size $34 \times 25 \times 1$ is used. The hidden layer consists of sigmoidal neurons and their outputs are fed into another layer called the context layer.

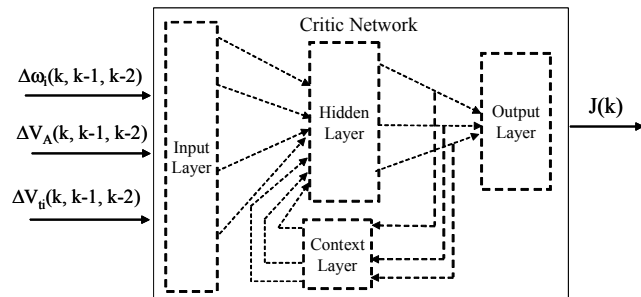

Figure 8. A recurrent neural network implementation for the critic network in Fig. 7 with 34 inputs at time instances $k+1$, k and $k-1$ in the input layer, 25 inputs in the context layer from the outputs of the 25 sigmoidal neurons in the hidden layer.

The training procedure of the critic network is similar to that reported in [6, 9] for the HDP approach. The identification networks have to be trained prior to training the critic network and this is explained in the next section. In [6, 9], the critic network was implemented using feedforward neural networks trained with the standard backpropagation. RNNs are known to be dynamic neural networks with the ability to approximate fast changing dynamic systems better than feedforward neural networks [10]. Therefore, all the neural networks used in this study are RNNs since dynamic optimization requires powerful neural network architectures. It is known that training of RNNs requires powerful algorithms; hence, the backpropagation through time (BPTT) algorithm with a truncation depth of ten is used in this paper [11].

The next section describes how the identification and control of the IEEE14 bus generators and UPFC shown in Fig. 1 is carried out using ObjectNets.

IV. IMPLEMENTATION OF THE IDENTIFICATION AND CONTROL OBJECTNETS

In a large power system, the dynamics is high nonlinear and complex, therefore, a number of signals some which are similar but measured at different buses on the system, have to be predicted or estimated for effective control of the system. ObjectNets are suitable when intelligent control is chosen as the alternative and the system is large and scalability becomes an issue. ObjectNets are neural network based designs and may constitute recurrence of hidden layer and output layer outputs. ObjectNets are similar to agents accomplishing specific tasks. In order to minimize the terminal voltage deviations of a generator, a neural network identifier can be trained to predict the terminal voltage deviations and used in the design of an intelligent controller [1]. With recurrence in

the identifier architecture, the same neural network can be used to predict the terminal voltage deviations of a second different generator with a very small amount of training if required. And this can be used on any generator of similar type and dynamics. This neural network is referred to as ObjectNet and specifically called in this paper an identifier of generator terminal voltage deviation (ID_Gen_Voltage_Net). The same concept is extended to the controller design, control of generator terminal voltage (CO_Gen_Voltage_Net). This approach reduces the computational time and effort in the development of such intelligent identifiers and controllers for all generators in a large scale power network individually.

Figs. 9 and 10 show the inputs and outputs of the ID_Gen_Voltage_Net and CO_Gen_Voltage_Net developed for generator G_i . The ID_Gen_Voltage_Net and CO_Gen_Voltage_Net of G_i are duplicated for G_2, G_3, G_4 and G_5 .

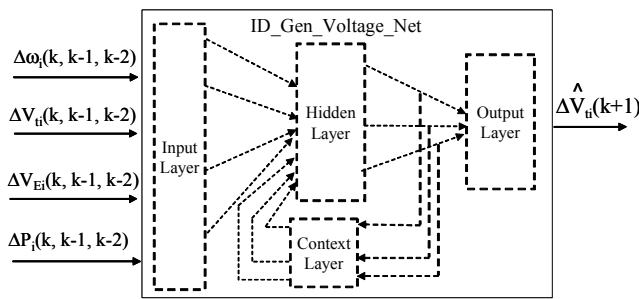

Figure 9. A block diagram of the identifier ObjectNet for identifying the terminal voltage deviations of a generator G_i .

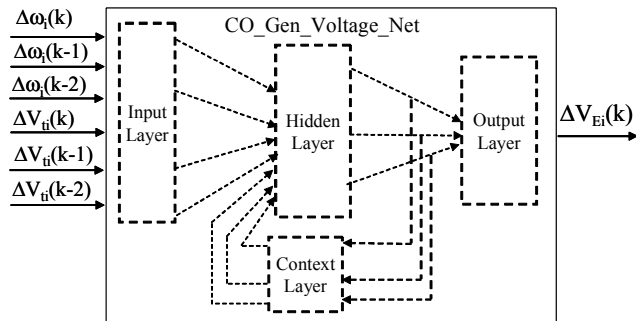

Figure 10. A block diagram of the controller ObjectNet for controlling the terminal voltage deviations of a generator G_i .

In addition to the above identifier and controller for the terminal voltage deviations, a number of other identifiers and controllers based on the ObjectNet concept are developed in this paper, namely:

- For controlling the turbine and governor combination, an ObjectNet called the identifier of generator speed deviations (ID_Gen_Speed_Net) and a second ObjectNet called the controller of generator speed deviations (CO_Gen_Speed_Net) is developed for G_1 and duplicated for G_2 . Figs. 11 and 12 show the inputs and outputs of the ID_Gen_Speed_Net and CO_Gen_Speed_Net developed for generator G_i .

- For controlling the shunt branch of the UPFC, two identifier and two controller ObjectNets are developed as explained below:

- Two ObjectNets are designed to identify the deviation signals of shunt branch. One is to identify the bus voltage deviations (ID_Bus_Voltage_Net) and the other to identify the dc capacitor voltage deviations (ID_DC_Voltage_Net). Figs. 13 and 14 show the inputs and outputs of the ID_Bus_Voltage_Net and ID_DC_Voltage_Net developed for a UPFC.
- Two ObjectNets are designed to control the deviation signals of shunt branch. One is to control the bus voltage deviations (CO_Bus_Voltage_Net) and the other to control the dc capacitor voltage deviations (CO_DC_Voltage_Net). Figs. 15 and 16 show the inputs and outputs of the CO_Bus_Voltage_Net and CO_DC_Voltage_Net developed for a UPFC.

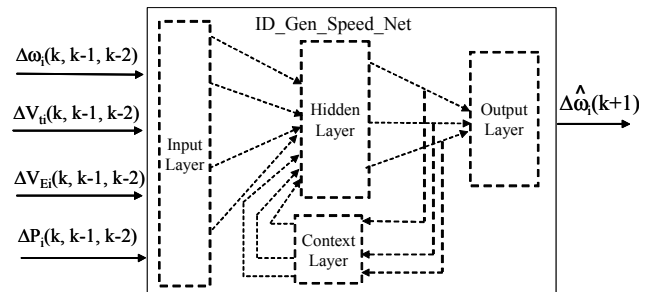

Figure 11. A block diagram of the identifier ObjectNet for identifying the speed deviations of a generator G_i .

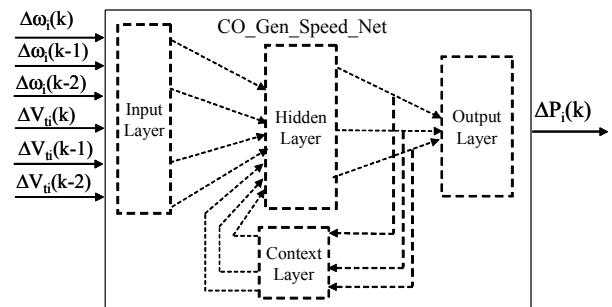

Figure 12. A block diagram of the controller ObjectNet for controlling the speed deviations of a generator G_i .

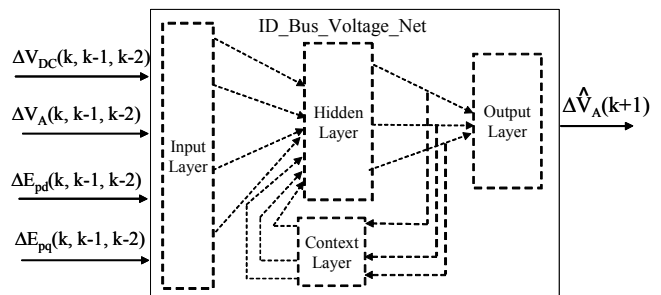

Figure 13. A block diagram of the identifier ObjectNet for identifying the voltage deviations at a UPFC shunt bus.

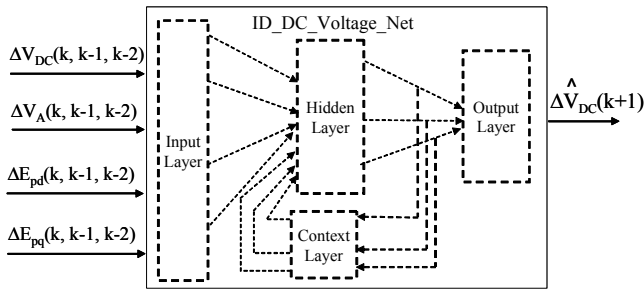

Figure 14. A block diagram of the identifier ObjectNet for identifying the dc capacitor voltage deviations of a UPFC.

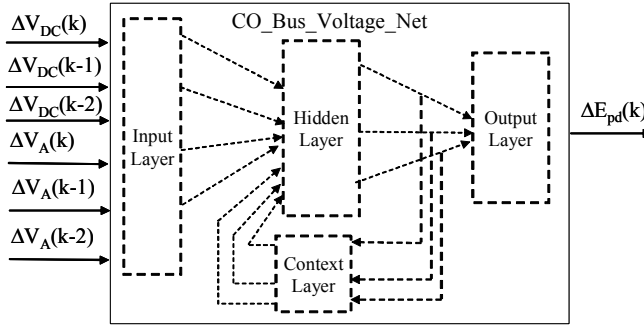

Figure 15. A block diagram of the controller ObjectNet for controlling the voltage deviations at a UPFC shunt bus.

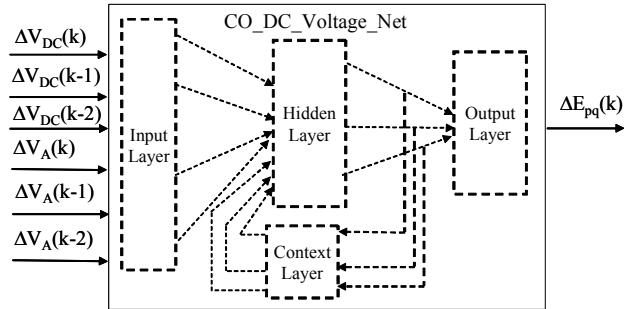

Figure 16. A block diagram of the identifier ObjectNet for controlling the dc capacitor voltage deviations of a UPFC.

The identifier ObjectNets shown above are trained by applying pseudorandom random signals (PRBS): ΔV_{Ei} , ΔE_{pd} , ΔE_{pq} , causing deviations of magnitudes up to $\pm 15\%$ in V_{ti} , V_A and V_{dc} respectively. PRBS signal - ΔP_i is applied to cause $\pm 10\%$ in the input power reference signal to the turbines of generators G1 and G2. For generators G3, G4 and G5 which have no turbine-governor setup, ΔP_i is set to zero. The BPTT training algorithm is used for training the identifiers. There are twelve identifiers installed on the IEEE 14 bus system (G1 - 2, G2 - 2, G3 - 2, G4 - 2, G5 - 2 and UPFC shunt branch -2). In other words, there are four ObjectNet identifiers that are developed - five *speed* deviations identifiers and five *terminal voltage* deviations identifiers for the five generators; and, one *bus voltage* deviation identifier and one *dc capacitor voltage* identifier for the UPFC.

The controllers shown in Figs. 10 and 12 replace the conventional AVR and governor shown in Figs. 2 and 3 respectively for all the generators in the IEEE 14 bus system. Likewise, the controllers shown in Figs. 15 and 16 replace the PI controllers for the shunt branch of the UPFC shown in Fig. 5. There are nine controllers installed on the IEEE 14 bus system (G1 - 2, G2 - 2, G3 - 1, G4 - 1, G5 - 1 and UPFC shunt branch -2). In other words, there are four ObjectNet controllers that are developed - two *speed* deviations controllers for generators G1 and G2; five *terminal voltage* deviations controllers for the five generators; and, one *bus voltage* deviation controller and one *dc capacitor voltage* controller for the UPFC. The critic network provides a dynamic feedback signal to each of the controllers to correct their performance as shown in Fig. 7 in order to minimize J given by (1).

V. RESULTS

The ObjectNets have been implemented in FORTRAN which is embedded into PSCAD/EMTDC software in which the IEEE 14 bus power system with the UPFC has been simulated. Results are presented below for the identifier ObjectNets, critic network and controller ObjectNets.

A. Identifier ObjectNets

Two ObjectNets namely ID_Gen_Voltage_Net1 and ID_Gen_Speed_Net1 are trained on generator G1 for 2000s. The training samples are obtained every 10 ms. A sampling frequency of 100 Hz is more than sufficient to identify the power system dynamics from a generator control point of view. Figs. 17 and 18 show the terminal voltage deviation and the speed deviation of generator G1 when training with PRBS signals starts with random weights for RNNs at 20s. The outputs of the generators/UPFC are shown in green lines and the estimated outputs of RNNs are shown in blue lines in all the figures below.

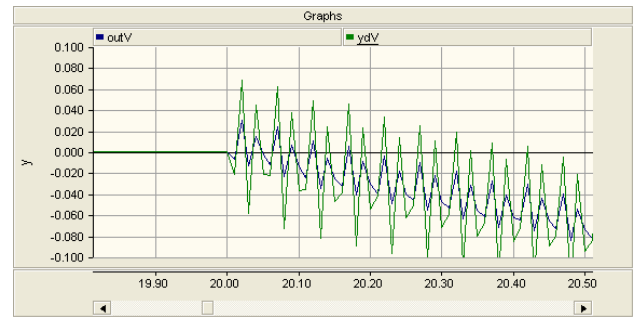

Figure 17. Actual terminal voltage deviation of generator G1 and the estimated output of the ID_Gen_Voltage_Net1 when PRBS signals are applied to G1's excitation and turbine at 20s.

A typical PRBS signal applied to generator G1's excitation system is given in Fig. 19. After 190s of training, the mean square error (MSE) between the actual speed deviation of G1 and the estimated output of the identifier ObjectNet ID_Gen_Speed_Net1 is shown in Fig. 20. It can be seen that the MSE is in order of 10^{-4} .

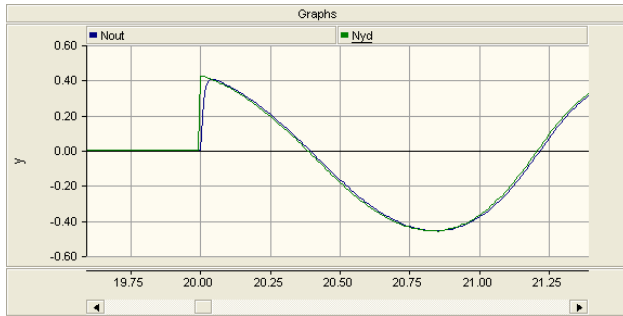

Figure 18. Actual speed deviation of generator G1 and the estimated output of the ID_Gen_Speed_Net1 when PRBS signals are applied to G1's excitation and turbine at 20s.

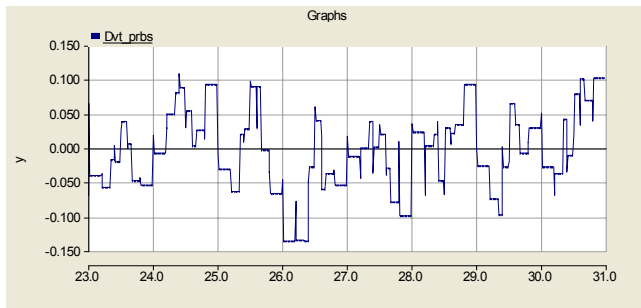

Figure 19. PRBS signal applied to generator G1's excitation system..

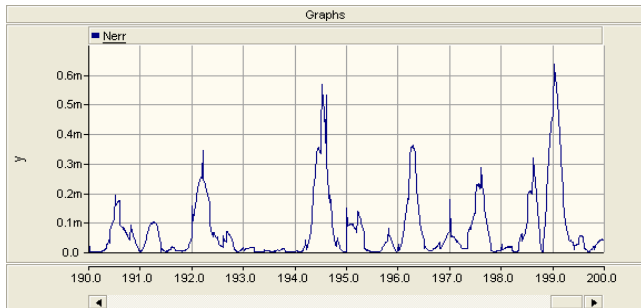

Figure 20. Mean square error between the actual speed deviation of G1 and the estimated speed deviation by the identifier ObjectNet ID_Gen_Speed_Net1 after 190s of training with PRBS signals.

After the training has been completed on G1, the identifier ObjectNets's weights are transferred to those on generator G2 (ID_Gen_Voltage_Net2 and ID_Gen_Speed_Net2). With the weights kept fixed, testing is done to check how good are the estimations of ObjectNets on G2's terminal voltage and speed deviations. It was found with this test that MSE is in order of 10^{-3} when the excitation system and turbine of G2 are subjected to PRBS signals. The speed deviation of G2 is shown in Fig. 21. Generator G2 is different from G1 in terms of its parameters and size. The low MSE is due to the recurrence capability added to the identification neural network. With a further training of 100s, the MSE falls in the order of 10^{-4} .

A similar observation was made for the speed deviation ObjectNets of G3, G4 and G5 and, the terminal voltage deviations ObjectNets of G2, G3, G4 and G5. The advantage

of the ObjectNet concept is that RNNs can be used to develop fast adaptive accurate models with lesser training time. Thus, for a large power system with hundreds of generators, training time reduction will be tremendous.

In order to train the ObjectNet identifiers for the UPFC shunt inverter control, PRBS signals are added to the bus voltage A reference and the dc capacitor voltage reference (Fig. 5). A sampling frequency of 2 kHz is used to capture the fast dynamics of the UPFC. Testing results are shown in Figs. 22 and 23 with weights of the RNNs fixed after 1900s of training. Once again, the MSE is in the order of 10^{-4} . Since the IEEE 14 bus power system of Fig. 1 has only one UPFC, the ObjectNets ID_Bus_Voltage_Net and ID_DC_Voltage_Net could not be tested on another UPFC.

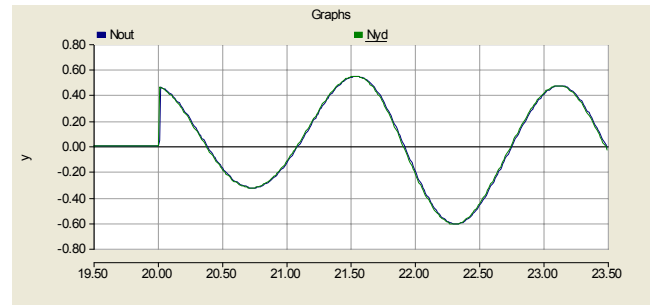

Figure 21. Actual speed deviation of generator G2 and the estimated output of the ID_Gen_Speed_Net2 when PRBS signals are applied to G2's excitation and turbine at 20s with fixed weights of ID_Gen_Speed_Net1.

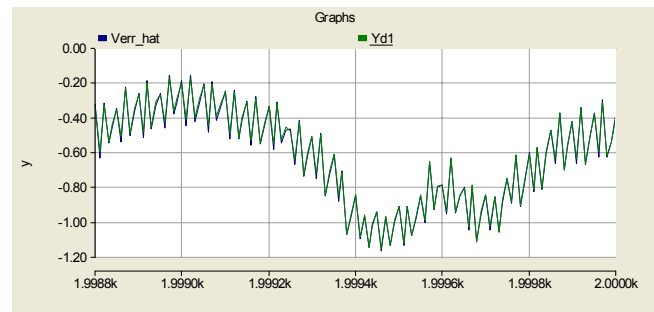

Figure 22. Actual UPFC shunt bus voltage deviation and the estimated output of the ID_Bus_Voltage_Net (with fixed weights) when PRBS signals are applied to shunt bus voltage reference V_{AREF} and dc capacitor voltage reference V_{dcREF} and training have been terminated at 1900s.

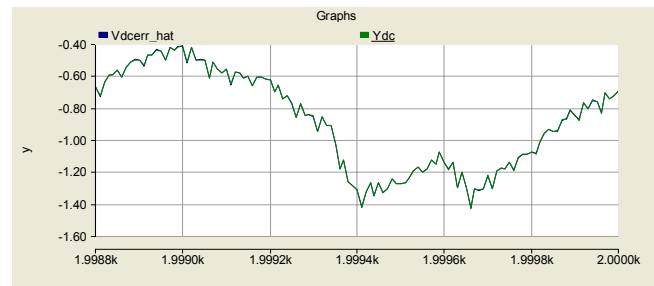

Figure 23. Actual UPFC dc capacitor voltage deviation and the estimated output of the ID_DC_Voltage_Net (with fixed weights) when PRBS signals are applied to shunt bus voltage reference V_{AREF} and dc capacitor voltage reference V_{dcREF} and training have been terminated at 1900s.

B. Critic Network

The critic network described in Section III above is trained by applying PRBS signals to the generators and the UPFC reference signals. The critic training is carried out until the output of the critic has settled around a steady state value J . This is carried out for a number of operating conditions. The critic output is shown below for two cases: (i) Fig. 24 shows J when PRBS signals are applied to generator G1 and (ii) Fig. 25 shows J when PRBS signals are applied to reference signals of the shunt inverter of the UPFC. The utility function $U(k)$ used for the critic training is given by (4) and the discount factor used is 0.5 [7, 9].

$$U_1(k) = 4[\Delta V_{i1}(k) + \Delta V_{i2}(k) + \Delta V_{i3}(k) + \Delta V_{i4}(k) + \Delta V_{i5}(k) + \Delta V_A(k)] + 4[\Delta V_{i1}(k-1) + \Delta V_{i2}(k-1) + \Delta V_{i3}(k-1) + \Delta V_{i4}(k-1) + \Delta V_{i5}(k-1) + \Delta V_A(k-1)] + 16[\Delta V_{i1}(k-2) + \Delta V_{i2}(k-2) + \Delta V_{i3}(k-2) + \Delta V_{i4}(k-2) + \Delta V_{i5}(k-2) + \Delta V_A(k-2)] \quad (2)$$

$$U_2(k) = 0.4[\Delta \omega_1(k) + \Delta \omega_2(k) + \Delta \omega_3(k) + \Delta \omega_4(k) + \Delta \omega_5(k)] + 0.4[\Delta \omega_1(k-1) + \Delta \omega_2(k-1) + \Delta \omega_3(k-1) + \Delta \omega_4(k-1) + \Delta \omega_5(k-1)] + 0.16[\Delta \omega_1(k-2) + \Delta \omega_2(k-2) + \Delta \omega_3(k-2) + \Delta \omega_4(k-2) + \Delta \omega_5(k-2)] \quad (3)$$

$$U(k) = U_1^2(k) + U_2^2(k) \quad (4)$$

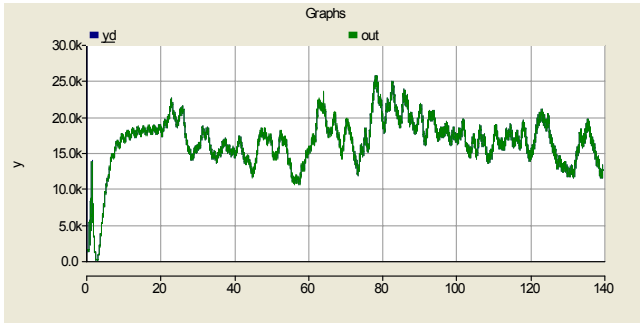

Figure 24. Critic network output J for PRBS signals applied to generator G1 reference signals of exciter and turbine.

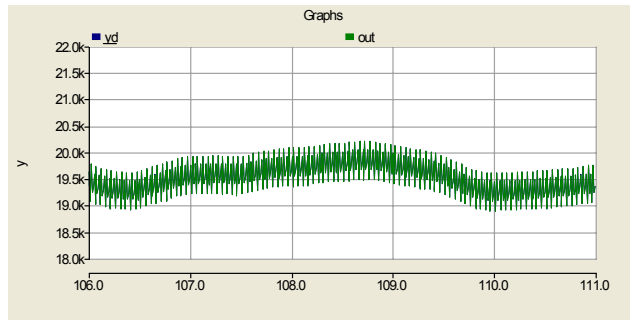

Figure 25. Critic network output J for PRBS signals applied to UPFC shunt inverter reference signals of bus A voltage and dc capacitor voltage.

C. Controller ObjectNets

The four different controller ObjectNets are developed. The training of the ObjectNet controller is similar to those controllers described in [6, 9]. PRBS signals are applied to the reference signals of the generators and the UPFC one at a time. The respective error signals are generated by the converged critic network through the respective identification ObjectNets developed above for the controllers' training.

The controller training is interleaved with the critic training with PRBS signals until the critic output has stabilized and the error signals generated for controllers are almost zero. Once this state is attained, then the controller ObjectNets weights are fixed. Three phase short circuits disturbance are applied at different buses on the IEEE 14 bus power system to test the effectiveness of the ObjectNet controllers developed.

Figs. 26 and 27 show the terminal voltage deviation of generators G1 and G2 for a 200ms three phase short circuit halfway between buses 1 and 2. Fig. 28 shows the UPFC shunt bus voltage for a 200ms short circuit place between buses 1 and 2. Fig. 29 shows the UPFC shunt bus voltage for a 100ms short circuit place between buses 2 and 3. In this case, the fault is directly on the UPFC shunt bus. Similar tests have been carried out at different buses and the ObjectNets based controllers are found to provide good damping of the transient disturbances.

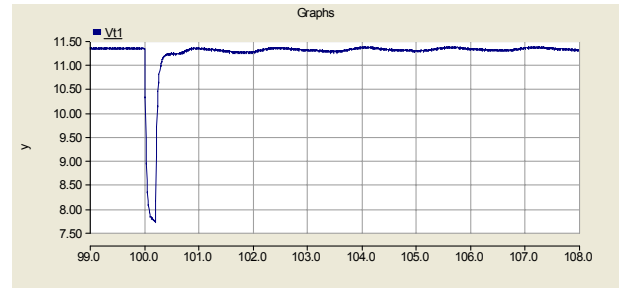

Figure 26. Terminal voltage deviation of generator G1 for a 3 phase 200ms short circuit between buses 1 and 2.

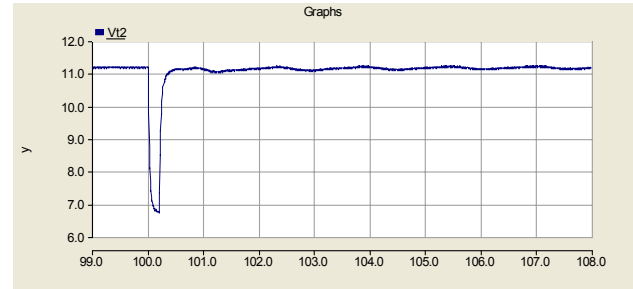

Figure 27. Terminal voltage deviation of generator G2 for a 3 phase 200ms short circuit between buses 1 and 2.

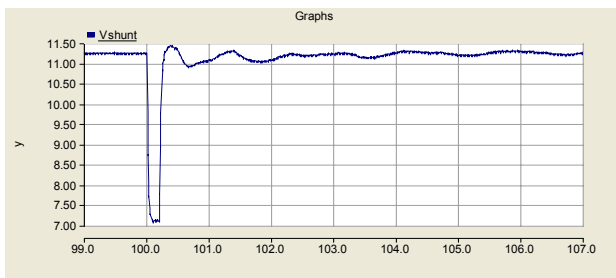

Figure 28. UPFC shunt inverter bus voltage for a 3 phase 200ms short circuit between buses 1 and 2.

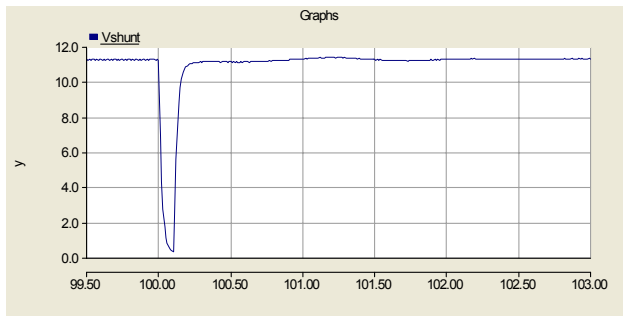

Figure 29. UPFC shunt inverter bus voltage for a 3 phase 100ms short circuit between buses 2 and 3.

VI. CONCLUSION

This paper has presented a novel strategy to carry out dynamic optimization of multimachine power systems using adaptive critic designs. A new concept of using ObjectNets for identification and control of elements of a large power system has been introduced and implemented on the IEEE 14 bus system. This strategy births the potential for scalability of intelligent techniques to carry out dynamic optimization on large scale networks such as electric power grid. Designing individual intelligent identifiers and controllers will be not practical with large systems and this is overcome with the concept of ObjectNets.

The ObjectNets presented in this paper can also be referred to as agents accomplishing specific tasks such identification, local control and optimization. The proposed framework in this paper can be viewed as a multi-agent based control scheme to achieve minimization of voltage and speed deviations in a power system. To extent this framework to large power systems, the multi-agent scheme will have to be implemented on a wide area based control/optimization scheme using a bottom-up approach. Future work involves evaluating these new concepts on a large power system with multiple FACTS devices and generators located in many areas.

ACKNOWLEDGEMENT

The support from the National Science Foundation under the CAREER Grant: ECS # 0348221 is gratefully acknowledged for this work.

REFERENCES

- [1] G.K. Venayagamoorthy, R.G. Harley, "Two separate continually online-trained neurocontrollers for excitation and turbine control of a turbo generator", *IEEE Transactions on Industry Applications*, vol. 38 no. 3, pp. 887 -893, June 2002.
- [2] R. P. Kalyani, G.K.Venayagamoorthy, "Two separate continually online trained neurocontroller for a unified power flow controller", *IEEE IAS 38th Annual Meeting*, October 2003, pp. 308-315.
- [3] R.M. Mathur, R. K. Varma, *Thyristor-based FACTS controllers for electrical transmission systems*, IEEE Press and John Wiley and Sons, Inc., ISBN 0-471-20643-1, 2002.
- [4] P. J. Werbos, "ADP: Goals, Opportunities and Principles", *Learning and approximate dynamic programming - scaling up to the real world*, Wiley, 2004.
- [5] N. G. Hingorani, L. Gyugyi, *Understanding FACTS concepts and technology of flexible AC transmission systems*, IEEE Press, ISBN 0-7803-3455-8, 2000.
- [6] J. W. Park, R.G.Harley, G.K.Venayagamoorthy, "Adaptive critic based optimal neurocontrol for synchronous generator in power system using MLP/RBF neural networks", *IEEE Transactions on Industry Applications*, vol. 39, no. 5, October 2003, pp. 1529-1540.
- [7] G. K. Venayagamoorthy, R. G. Harley, D. C. Wunsch, "Dual heuristic programming excitation neurocontrol for generators in a multimachine power system", *IEEE Transactions on Industry Applications*, vol. 39, no. 2, March/April 2003, pp. 382 to 394.
- [8] P. Kundur, et al., "Definition and classification of power system stability", *IEEE Transactions on Power Systems*, 2004, pp. 1 - 15.
- [9] G. K. Venayagamoorthy, R. G. Harley, D. C. Wunsch, "Comparison of heuristic dynamic programming and dual heuristic programming adaptive critics for neurocontrol of a turbogenerator", *IEEE Transactions on Neural Networks*, vol. 13, no. 3, May 2002, pp. 764-773.
- [10] J. F. Kolen, S. C. Kremer, *A field guide to dynamical recurrent networks*, IEEE Press, 2001, ISBN 0-7803-5369-2, edited by Kolen and Kremer.
- [11] P. J. Werbos, "Backpropagation through time: What it does and how to do it?" *Proceedings of IEEE*, 78, 1990, pp. 1550-1560.